

ver. 2.5

DESCRIPTION OF UPLOADABLE - DOWNLOADABLE CHARACTER GENERATOR FOR MCA2X16 LED DISPLAY CONTROLLERS

I.	General Description
II.	Construction of Character Generator
III.	Upload Character Generator
IV.	Download Character Generator
V.	Seven segment display segment signs and values and shift register relationship
VI.	Fourteen segment display signs and values and shift register relationship
VII.	Sixteen segment display signs and values and shift register relationship
VIII.	Seventeen segment display signs and values and shift register relationship

I. General Description

MCA2X16 has internal unloadable - downloadable character generator, that takes to user very simple way to drive 7, 14, 16, 17 segment indicators without complicated address and data manipulation. In practice user must sending only hexadecimal values for 7 segment indicators to be appearing on the LED display. Digit pointer is increment or decrement, depending of state of bit 2 in **STATUS** byte with the every received hexadecimal value for 7 segment indicator. By the same way LED Controller dump ASCII strings to LED Display 14, 16, 17 segment indicators.

II. Construction of Character Generator

Character Generator is a binary file that must be exactly 1024 bytes wide. This file starts always with 1Bh 3Fh and ends 55h. From address 02h to 1Bh holds values for seven segment indicators, from address 20h to 1FFh holds values for 14 segment indicators, from address 220h to 1FFh holds values for 16, 17 segment indicators described below. Character generator is written in LED Controller's non-volatile memory and required uploading - downloading only when editing of specific characters are needed.

Character generator for 14, 16, 17 segment indicators is located in our web site: <http://www.itsdisplays.com/products.htm/character16.bin> and can be downloaded for editing.

III. Upload Character Generator

Via using command No16 HOST sends to LED Controller character generator as block of file, and writes this block in non-volatile memory. When block is received, LED Controller checks file for volume, clear both LINES and writes new values. If uploaded character binary file value is different from 1024 bytes, LED Controller sends to HOST in Literal Mode "**INCORRECT VALUE**" or in HEX mode 55h (U). After completing of command depending of selected message mode, LED Controller send to HOST (44)h in HEX mode or '**DONE**' in literal mode. Characters will appear with the new shapes. Command value must be present in first two bytes of character generator file.

Another way to upload character generator, is to open DOS prompt in Windows environment. Set appropriate mode for serial channel as example :

C:\ mode com1:57600,n,8,1

After appropriate baud rate is set simply write next command in DOS prompt :

C:\ copy character.bin com1:/Z

When message "100% copied 1 file (s) copied." is appear in DOS prompt that mean that character generator is uploaded and written in non-volatile memory and can be used with new values. Refer to command set for more details.

IV. Download Character Generator

Using command No15 LED Controller sends to HOST character generator as block of file (1024 bytes). Character generator can be copied from our web: <http://www.itsdisplays.com/products.htm/character16.bin>. Character generator can be edited as user wish following described rules using suitable hexadecimal editor (supported with some EPROM/FLASH programmers) and after that can be easily to upload to LED Controller. Table below shows address map of character generator.

Description	Address	Value
First address	000h	1Bh
Second address	001h	3Fh
seven segment indicators signs	002h	Start address
	01Ah	End address
Not Used	From 01Bh to 01Fh	00h
fourteen segment indicators signs - capital and small letters	020h	Start address
	0DFh	End address
Not Used	From 0E0h to 21Fh	00h
16 - 17 segment indicators signs - capital and small letters	220h	Start address
	2DFh	End address
Not Used	From 2E0h to 3FEh	00h
Last address	3FFh	55h

Table 1

V. Seven segment Indicators segment signs and values and shift register relationship

From address 02h to 1Ah in character generator holds values signs for seven segment indicators. **Figure 2** below shown legend for **Table 2**. **Figure 1** point's exact relationship between segment of the seven segment indicator and outputs from shift registers. When connections between indicators and shift registers do not mach as points **Figure 1**, user needs to edit character generator to set segments in appropriate positions depending connections in his PCB board. **Picture 1** shows view of all shapes of real display, using internal character generator.

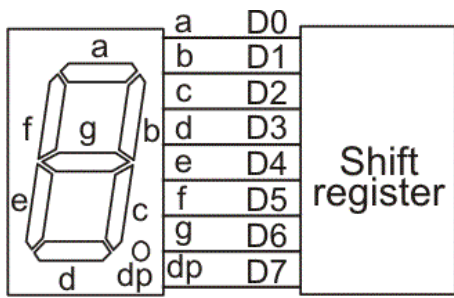

Figure 1

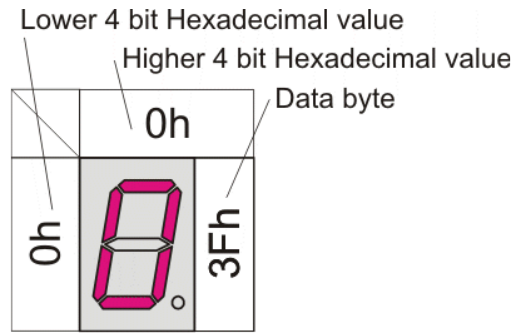

Figure 2



Picture 1

















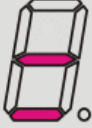







	0h	1h		0h	1h
0h	 3Fh	 80h	8h	 7Fh	
1h	 06h	 00h	9h	 6Fh	
2h	 5Bh		Ah	 77h	Not Used
3h	 4Fh		Bh	 7Ch	ESC
4h	 66h		Ch	 39h	Not Used
5h	 6Dh		Dh	 5Eh	Not Used
6h	 7Dh		Eh	 79h	Not Used
7h	 07h		Fh	 71h	Not Used

Table 2

VI. Fourteen segment display signs and values and shift register relationship

Fourteen segment display starts from address 20h in character generator. Each indicator display occupied two addresses. **Figure 3** points exact relationship between segment of the fourteen segment indicator and outputs from two sequential shift registers. **Figure 4** below shown legend for **Table 3**. For small letters from ASCII 61h to 7Fh signs are the same as capitals letters. From 0E0h up to 21Fh, character generator in this version is empty. **Picture 2** shows view of some shapes of real fourteen segment display, using internal character generator.

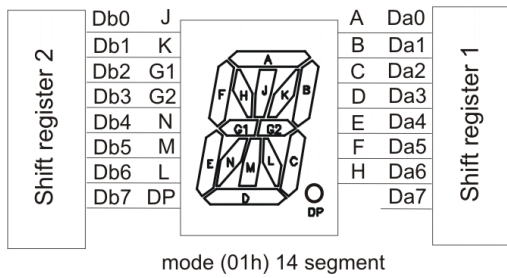

Figure 3

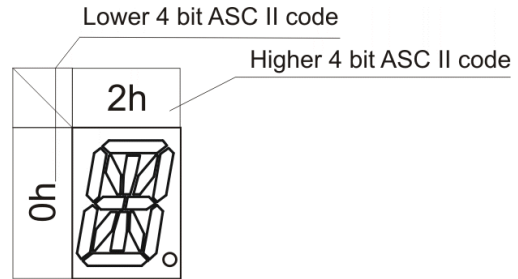

Figure 4



Picture 2

	2h	3h	4h	5h		2h	3h	4h	5h
0h					8h				
1h					9h				
2h					Ah				
3h					Bh				
4h					Ch				
5h					Dh				
6h					Eh				
7h					Fh				

Table 3

VII. Sixteen segment display signs and values and shift register relationship

Sixteen segment display starts from address 220h in character generator. Each indicator display occupied two addresses. **Figure 5** points exact relationship between segment of the sixteen segment indicator and outputs from two sequential shift registers. **Figure 6** below shown legend for **Table 4**. For small letters from ASCII 61h to 7Fh signs are the same as capitals letters. From 2E0h up to 3FEh, character generator in this version is empty. **Picture 3** shows view of some shapes of real sixteen segment display, using internal character generator.

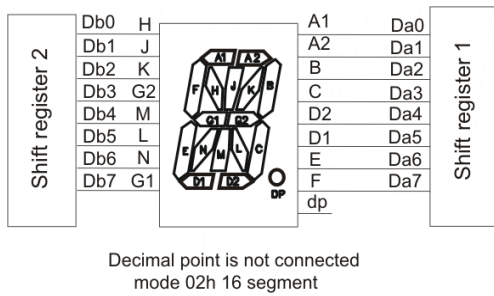

Figure 5

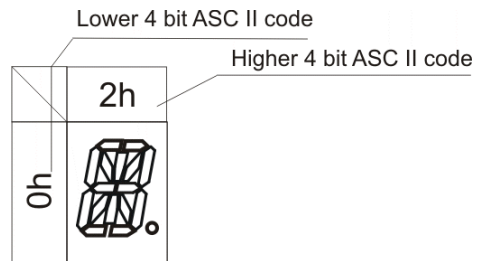

Figure 6



Picture 3

	2h	3h	4h	5h		2h	3h	4h	5h
0h					8h				
1h					9h				
2h					Ah				
3h					Bh				
4h					Ch				
5h					Dh				
6h					Eh				
7h					Fh				

Table 4

VIII. Seventeen segment display signs and values and shift register relationship

Seventeen segment displays use the same character generator. Each indicator display occupied two addresses. Additionally decimal point occupied one shift register for all 17 segment indicators. **Figure 7** points exact relationship between segments of the seventeen segment indicators and outputs from three sequential shift registers. For small letters from ASCII 61h to 7Fh signs are the same as capitals letters. In this case when 17segment mode is used, LED Controller can drive maximum 60 pieces of 17 segment indicators for each LINE. Seventeen segment display uses same character generator as sixteen segments except digital point, that is appears on DP segment.

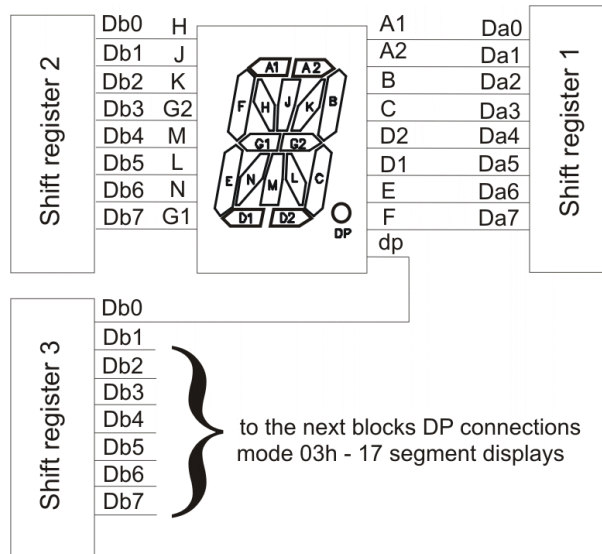

Figure 7

If you have any questions or find some mistakes in this document, do not hesitate to contact us on the next E-mails: its@itsdisplays.com or support@itsdisplays.com , and we try to answer you as soon as possible.

Copyright © ITS Displays PTE. All right reserved.